

# 2370

Dust Control Burnisher  
Máquina de Pisos

U.S. PATENT NO.: D.345,035 & 5,608,939

**Model No.:**  
**613202**  
**1000151**

**Operator and Parts Manual**  
**Manual del Operador y Piezas**

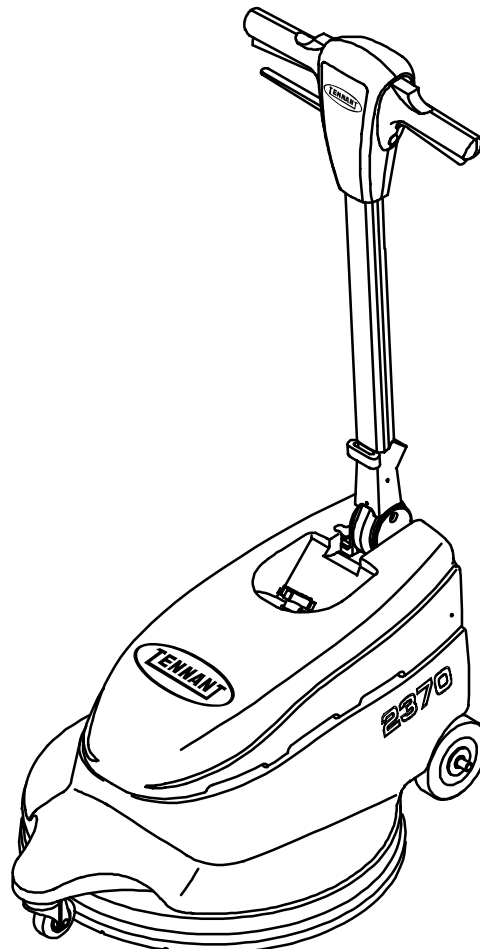

**TENNANT COMPANY**  
**Commercial Products**  
12875 RANSOM STREET  
HOLLAND MI 49424 U.S.A.

**CUSTOMER SERVICE:**  
1-800-982-7658  
1-616-786-2330

**FAX:** 1-800-678-4240  
1-616-786-2345

**1001921**  
**Rev. 01 (09-02)**

120V WIRING DIAGRAM

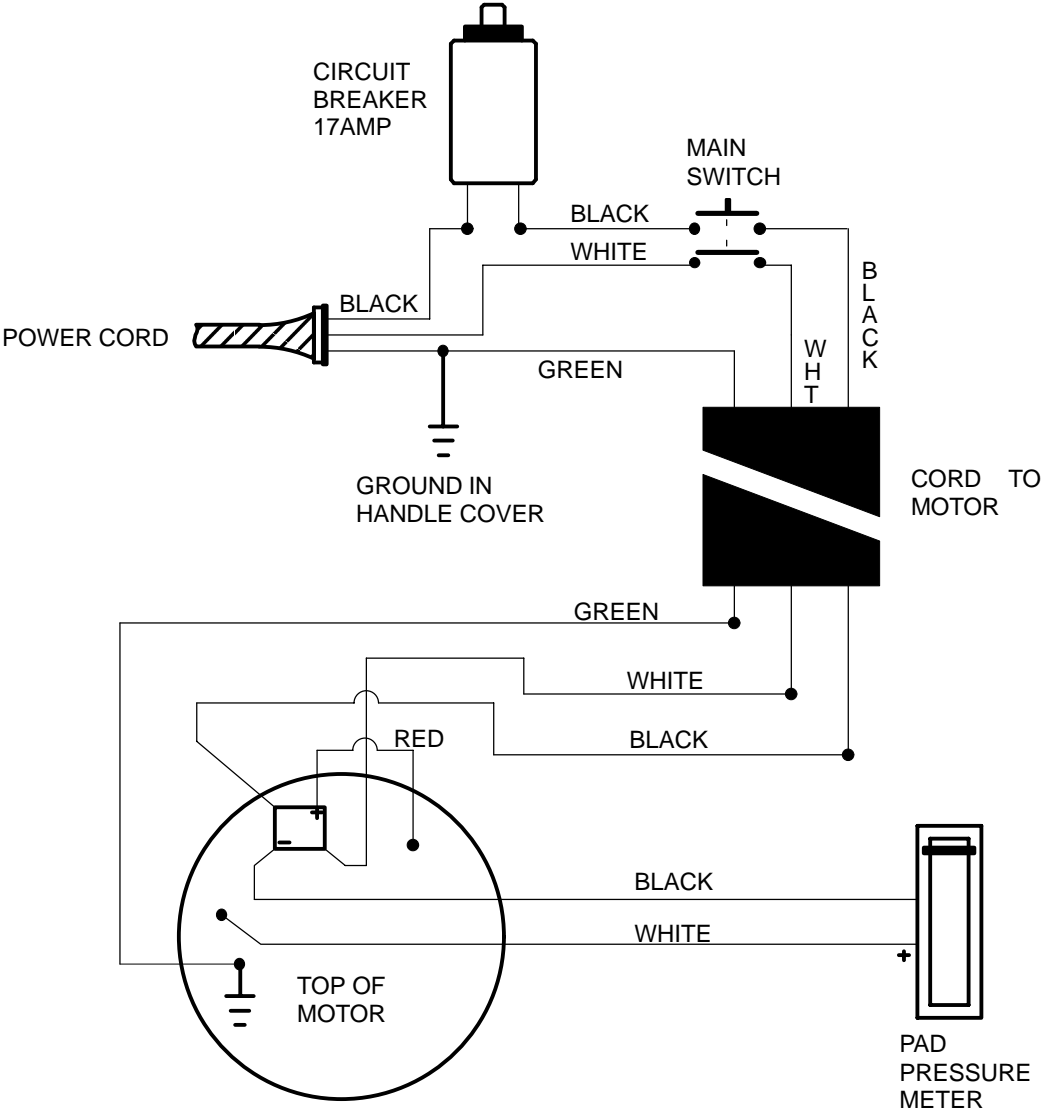

HANDLE GROUP  
GRUPO DE LE MANIJA

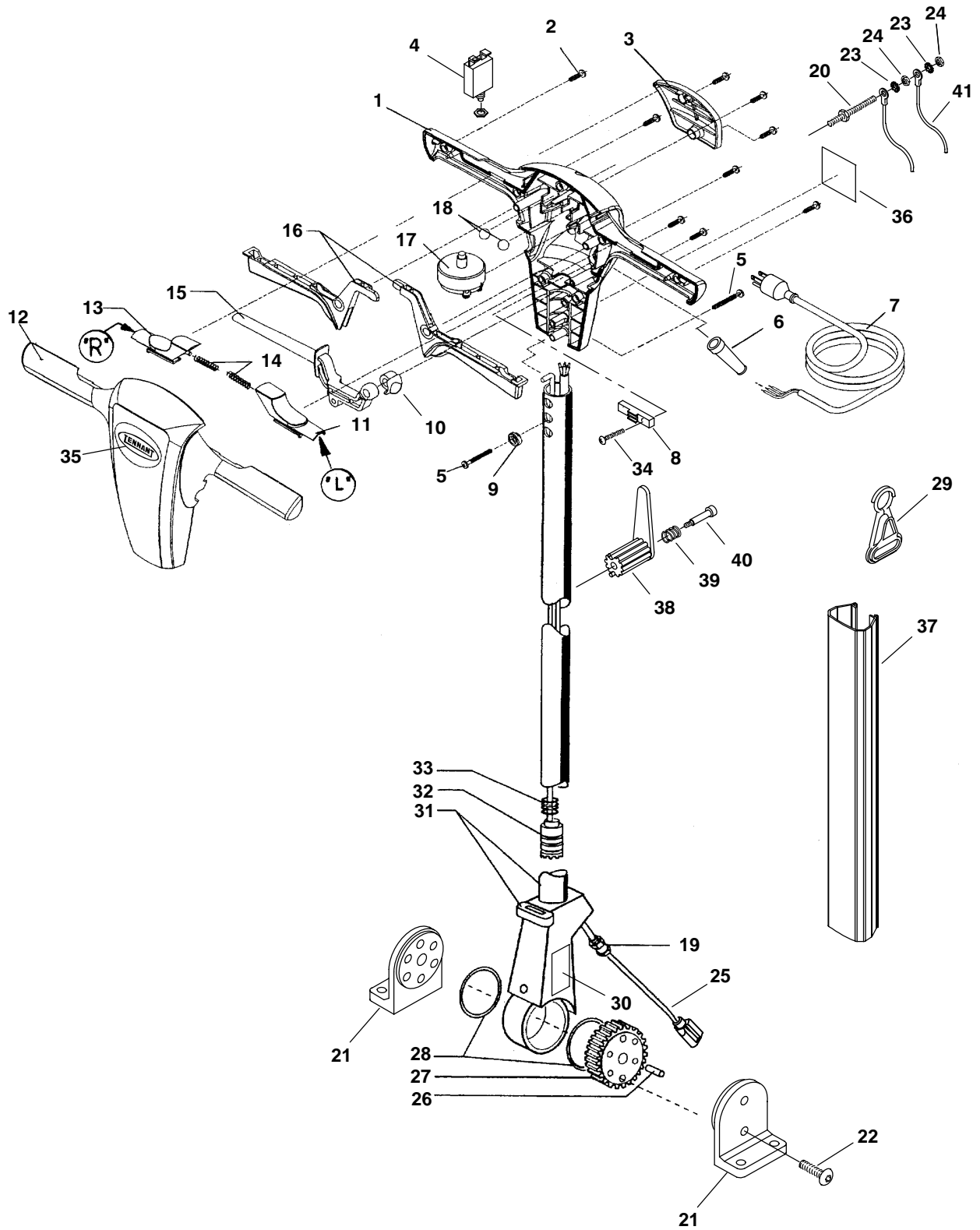

**HANDLE GROUP**  
**GRUPO DE LE MANIJA**

REF	PART #	DESCRIPTION	QTY
1	613268	HOUSING, HANDLE REAR	1
2	801274	SCREW	9
3	801003	COVER	1
4	1000209	●CIRCUIT BREAKER, 17AMP	1
5	801247	SCREW	2
6	801448	GRIP, CORD	1
7	1000480	●CORD, POWER 23M	1
8	99916617	CLAMP	1
9	99916544	INSERT	1
10	1000592	PLUG, LEVER HOLE	1
11	801005	SLIDE "L"	1
12	613264	HOUSING, HANDLE FRONT	1
13	801004	SLIDE "R"	1
14	801013	SPRING	2
15	801008	LEVER	1
16	801006	LEVER	2
17	1000479	●SWITCH	1
18	801035	BALL	2
19	99942168	GRIP, CORD	1
20	99918666	SCREW, DOUBLE THD SERIES	1
21	99918240	SUPPORT, HANDLE	2

REF	PART #	DESCRIPTION	QTY.
22	99915121	SCREW	4
23	99916598	WASHER, LOCK	2
24	99915658	NUT, HEX	2
25	1000517	CABLE, HANDLE	1
26	99918243	PIN	2
27	99918238	GEARWHEEL	1
28	99923586	RING	2
29	130176	●BELT CLIP, STRAIN-RELIEF (OPTIONAL)	
30	610185	LABEL, HAZARD UNPLUG	1
31	1002016	ASM., TUBE	1
32	1002017	ASM., ROD	1
33	99915228	SPRING	1
34	801449	SCREW	2
35	99918249	LABEL, "TENNANT"	1
36	578729	LABEL, READ MANUAL	1
37	1000760	COVER, HANDLE	1
38	603104	HOOK, CORD QUICK-RELEASE	1
39	603108	SPRING	1
40	140239	SCREW, 3/8X1-3/4 SHOULDER	1
41	1000512	ASM., WIRE	1

● RECOMMENDED STOCK ITEMS / ARTICULOS RECOMENDADOS

**BASE GROUP**  
**BASE GRUPO**

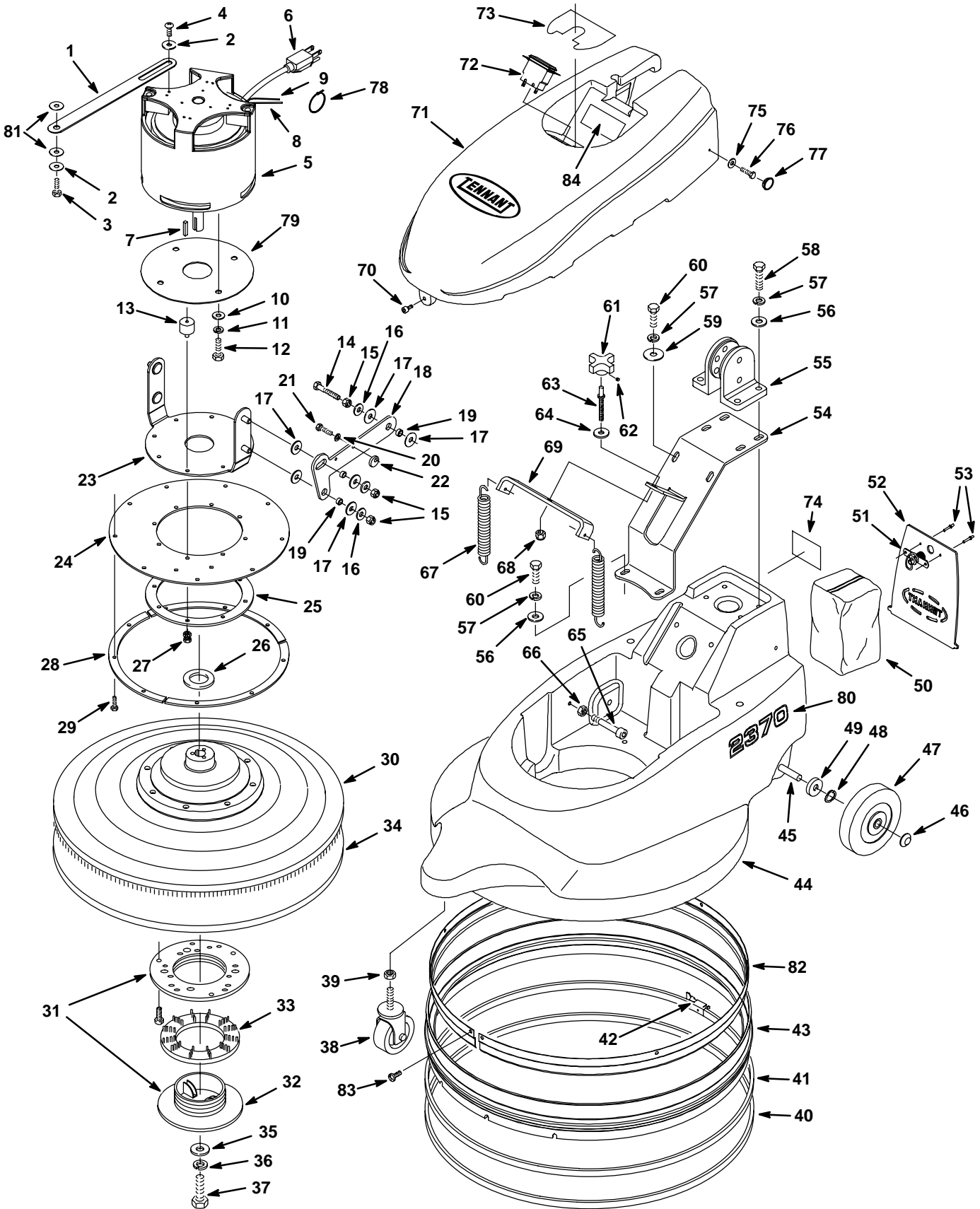

**BASE GROUP**  
**BASE GRUPO**

REF	PART #	DESCRIPTION	QTY.
1	1001200	STRAP, MOTOR STOP	1
2	140003	WASHER, 1/4X1 FENDER	2
3	140272	SCREW, M6X1.0X16	1
4	140350	SCREW, #10X1/2 PANPHL	1
▽	5	1000584 ●MOTOR, 2000RPM 1.5HP 115V	1
▲	22117	●BRUSH, CARBON	4
▲	190753	●RECTIFIER	1
▲	6	1001679 CORD, MOTOR	1
▲	7	140628 KEY, 3/16X3/16X1.0"	1
▲	8	1000483 ASM, WIRE #14X400BLK 1/4FX1/4F	1
▲	9	1000484 ASM, WIRE #14X400WHT 1/4FX10R	1
10	140028	WASHER, FLAT 3/8	4
11	140017	WASHER, LOCK .38	4
12	2949.5	SCREW, HEX .38-16X.62	4
13	1000409	MOUNT, STUD/PLATE	4
14	140233	SCREW, 3/8-16X1-3/4	2
15	600200	NUT, 3/8-16 JAM NYLOCK	6
16	140028	WASHER, FLAT 3/8	6
17	630477	WASHER, M12.7X25.4X.8 NYLON	12
18	611859	BRACKET, LIFT ARM	2
19	600191	SLEEVE, .50DX.375BX.23L STEEL	6
20	140016	WASHER, LOCK .25	2
21	140272	SCREW, M6X1.0X16 HXHDCP	2
22	1001408	CAM, STOP	2
23	611862	BRACKET, MOTOR	1
24	1000703	SEAL, RUBBER	1
25	1000713	PLATE, MOTOR MOUNT SEAL	1
26	069760023	WASHER, .77BX1.26DX.03	1
27	140524	NUT, 1/4-20 KEP	8
28	1000711	PLATE, BASE SEAL	3
29	140272	SCREW, M6X1.0X16 HXHDCP	9
▽	30	605348 ●ASM., DRIVER PAD 20" W/HUB	1
▲▽	31	25707 ASM., CENTERLOCK	1
▲	32	100101 RING, PAD RETAINER	1
33	572084000	●WASHER, PAD DRIVER LOCK	1
34	611788	●PAD, 20" BURNISH HAIRBLEND 1 CARTON = 5 PADS	1
35	25732	WASHER, .36BX1.25DX.93 FLAT	1
36	140015	WASHER, LOCK .31	1
37	140221	SCREW, 5/16-18X1-1/4 HXHDCP	1
38	600189	CASTER, 2-1/2 SWIVEL	1
39	140509	NUT, 1/2-13 HXJM	1
40	630613	STRIP, SKID	1

REF	PART #	DESCRIPTION	QTY.
41	069767094	KIT, BAND REPLACEMENT	1
42	602044000	FASTENER, ADJUSTING SKIRT	1
43	1005629	●SKIRT, DUST CONTROL	1
44	1000773	BASE, TEAL	1
45	1001193	AXLE, .5" DIA X 14.72" LG	1
46	103019	CAP, HUB	2
47	1001369	WHEEL, 5"X1.5 GRAY	2
48	4252	WASHER, 1/2 COMPRESSION	2
49	140063	WASHER, .51X1.25X.25	2
50	1000617	●FILTER, BAG	1
51	140962	LATCH, SPRING KNURLED	1
52	1000670	DOOR, BAG	1
53	140706	RIVET, POP 1/8	2
54	1000225	BRACKET, HANDLE SUPPORT	1
55	99918240	SUPPORT, HANDLE	2
56	140027	WASHER, FLAT .31	7
57	140015	WASHER, LOCK .31	8
58	09023	SCREW, HEX M08X1.25X35	4
59	140014	WASHER, 5/16X1-1/2 FENDER	1
60	140275	SCREW, M8X1.25X16 HXHDCP	4
▽	61	600974 ●KNOB, W/SET SCREW	1
▲	62	140894 SCREW, SET 10-32X1/4	1
63	611865	STUD, ADJUSTER	1
64	630447	WASHER, M12.7X25.4X.8 NYLON	1
65	200001486	SCREW, M8X1.25X16	2
66	200101017	NUT, M8X1.25 HXJM	2
67	1001422	SPRING, EXT .75X.095X3.75	2
68	600200	NUT, 3/8-16 JAM NYLOCK	1
69	600194	BRACKET, SPRING	1
70	200001483	SCREW, M8X1.25X12	1
71	1000156	COVER, MOTOR TEAL	1
72	1000489	●GAUGE, PAD PRESSURE	1
73	612771	LABEL, PAD PRESSURE	1
74	602597	LABEL, WARNING CSA	1
75	140000	WASHER, FLAT 1/4	2
76	140272	SCREW, M6X1.0X16 HXHDCP	2
77	130175	PLUG, DOME .75OD BLACK	2
78	130040	WIRE TIE	1
79	1001311	RETAINER, SEAL	1
80	612769	LABEL, "2370"	2
81	575600	WASHER, .25X1.06 NEOPRENE	2
82	1005645	SHIELD, SKIRT	1
83	140350	SCREW, #10X1/2 PANPHL	6
84	613286	LABEL, WARNING	1

▽ ASSEMBLY / CONJUNTO

▲ INCLUDED IN ASSEMBLY / INCLUIDO EN EL CONJUNTO

● RECOMMENDED STOCK ITEMS / ARTICULOS RECOMENDADOS